

GHB RANGE

LED HIGH BAY LUMINAIRE



FEATURES

- Light Weight Design
- IP65 rated
- CRI >70
- Up to 112 Llm/tcW
- 50,000 hours lifetime
- Optional wire guard with flat glass lens
- Microwave, photocell and emergency options

DIMENSIONS

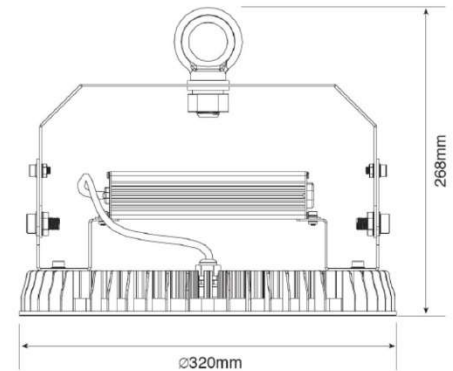

The GHB range is a range of LED high bay fittings that comes as standard as IP65 rated. The light weight, easy to install design coupled with a 50,000 hour life makes this ideal for factories, warehouses, sports centres and other similar applications.

The GHB is powder coated black with a choice of additional sensors – photocell or microwave, an optional cone reflector or a wire guard. The luminaire can also be fitted with emergency gear and is supplied with 5,000k colour temperature LED's as standard.

LUMINAIRE CAT NO.	NOMINAL SIZE MM	LUMEN OUTPUT*	POWER (tcW)	WEIGHT KG	DIM OPT	EM OPT
GHB215	320	16,372	147	5.4	•	•
GHB220	320	22,453	208	5.8	•	•
GHB230	320	37,565	301	6.4	•	•

* Lumen output of the luminaire with clear glass lens fitted

ADDITIONAL ORDERING INFORMATION

- DALI dimming - add /DALI
- Emergency version - add /EM
- Wire guard - add /WG
- Photocell - add / PC
- Microwave - add /PD
- Microwave sensor - add /MW